

# Rotary Position Sensors



## SMD/Lead Dust-proof Type 12mm Size SV01 Series

### ■ Features

1. Dust-proof construction protects the interior from dust, which maintains stable characteristics.
2. Compliant to high peak temperature lead free soldering.
3. Excellent resistance materials and high reliability wiper achieves 1M cycles.
4. D formation thru-hole rotor enables selection of any kind of gear shape.
5. Both D formation thru-hole rotor and T formation thru-hole rotor are available.
6. Leaded terminal type is available.
7. Ultra-thin size (2.1mm height)
8. Au plated terminals without Lead.

### ■ Applications

1. Animal robot
2. Switch for automotive
3. Motor drive unit
4. Radio control equipment
5. Electric motor-driven bicycle



SV01A

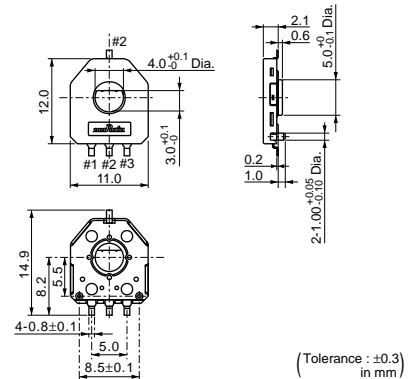

SV01L

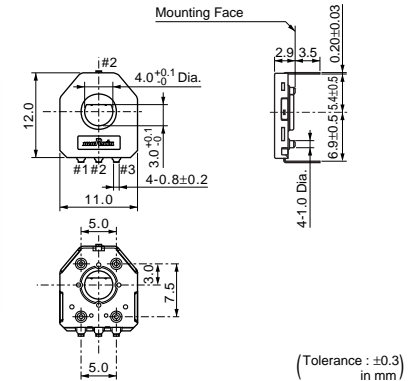

### ■ T formation Thru-hole rotor

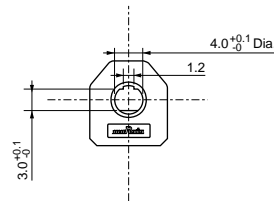

(Tolerance : ±0.3 in mm)

Part Number	Total Resistance Value (k ohm)	Linearity (%)	Effective Rotational Angle	TCR	Rotational Life
SV01A103□EA01	10 ±30%	±2	333.3° (Ref.)	±500ppm/°C	1M cycles
SV01L103□EA11	10 ±30%	±2	333.3° (Ref.)	±500ppm/°C	1M cycles

A blank column is filled with Rotor Formation Codes. (A: D formation thru-hole rotor C: T formation thru-hole rotor)

## Construction

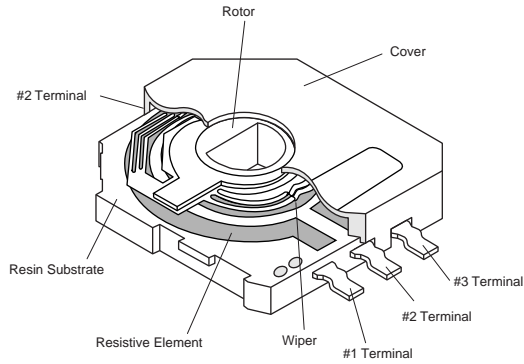

## Standard Land Pattern

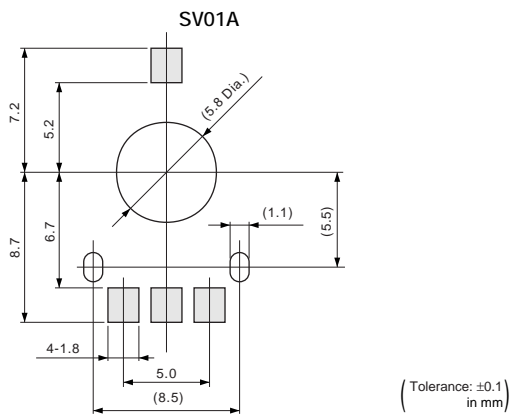

## Standard Mounting Holes

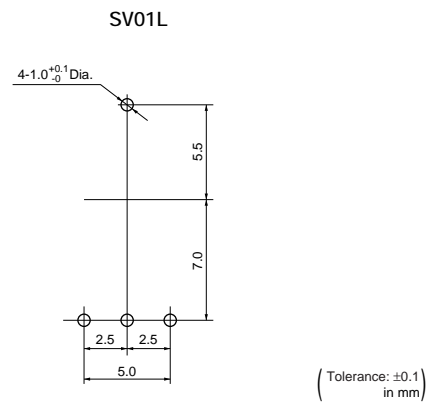

## Characteristics

Temperature Cycle (Thermal Shock)	ΔTR	±20%
	Linearity	±3%
Humidity	ΔTR	±20%
	Linearity	±3%
Vibration	ΔTR	±10%
	Linearity	±3%
Shock (20G)	ΔTR	±10%
	Linearity	±3%
Humidity Load Life	ΔTR	±20%
	Linearity	±3%
High Temperature Exposure	ΔTR	+5/-30%
	Linearity	±3%
Low Temperature Exposure	ΔTR	±20%
	Linearity	±3%
Rotational Life (1M cycles)	ΔTR	±20%
	Linearity	±3%

ΔTR: Total Resistance Change

## SV01 Series Notice

### ■ Notice (Operating and Storage Conditions)

1. Store in temperatures of -10 to +40deg. C and relative humidity of 30-85%RH.
2. Do not store in or near corrosive gases.
3. Use within six months after delivery.
4. Open the package just before using.
5. Do not store under direct sunlight.
6. Do not use the rotary position sensor under the following environmental conditions. If you use the rotary position sensor in an environment other than these listed below, please consult with Murata factory representative prior to using.
  - (1) Corrosive gasses atmosphere  
(Ex. Chlorine gas, Hydrogen sulfide gas, Ammonia gas, Sulfuric acid gas, Nitric oxide gas, etc.)
  - (2) In liquid  
(Ex. Water, Oil, Medical liquid, Organic solvent, etc.)
  - (3) Dusty / dirty atmosphere
  - (4) Direct sunlight
  - (5) Static voltage nor electric/magnetic fields
  - (6) Direct sea breeze
  - (7) Other variations of the above

### ■ Notice (Soldering and Mounting)

1. Soldering
  - (1) SV01 series can be soldered by reflow soldering method and soldering iron. Do not use flow soldering method (dipping).
  - (2) The dimension of land pattern used should be Murata's standard land pattern at reflow soldering. Excessive land area may cause displacement due to the effect of the surface tension of the solder. Insufficient land area may cause insufficient soldering strength on PCB. (SMD Type)
  - (3) Soldering condition  
Refer to the temperature profile.  
If the soldering conditions are not suitable, e.g., excessive time and/or excessive temperature, the rotary position sensor may deviate from the specified characteristics.
  - (4) The amount of solder is critical. Insufficient amounts of solder can lead to insufficient soldering strength on PCB. Excessive amounts of solder may cause bridging between the terminals.
    - (5) The soldering iron should not come in contact with the cover of the rotary position sensor. If such contact does occur, the rotary position sensor may be damaged.
2. Mounting
  - (1) Use PCB hole to meet the pin of the rotary position sensor. If the rotary position sensor is inserted into insufficient PCB hole, the rotary position sensor may be damaged by mechanical stress. (Lead type)
  - (2) Do not apply excessive force (preferable 9.8N (Ref.; 1kgf) max.), when the rotary position sensor is mounted to the PCB.
  - (3) Do not warp and/or bend PCB to prevent the rotary position sensor from breakage.
3. Cleaning  
Cannot be cleaned because of open construction.

## SV01 Series Notice

### ■ Soldering Profile

#### ● Reflow Soldering Profile

1. Soldering profile for Lead-free solder (96.5Sn/3.0Ag/0.5Cu)

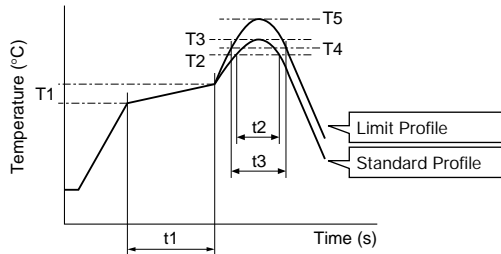

Standard Profile					
Pre-heating		Heating		Peak Temperature (T3)	Cycle of Reflow
Temp. (T1)	Time (t1)	Temp. (T2)	Time (t2)		
°C	sec.	°C	sec.	°C	Time
150 to 180	60 to 120	220	30 to 60	245±3	2

Limit Profile					
Pre-heating		Heating		Peak Temperature (T5)	Cycle of Reflow
Temp. (T1)	Time (t1)	Temp. (T4)	Time (t3)		
°C	sec.	°C	sec.	°C	Time
150 to 180	60 to 120	230	30 to 50	260 +5/-0	2

2. Soldering profile for Eutectic solder (63Sn/37Pb)  
(Limit profile: refer to 1)

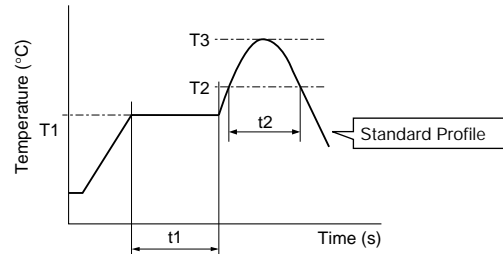

Standard Profile					
Pre-heating		Heating		Peak Temperature (T3)	Cycle of Reflow
Temp. (T1)	Time (t1)	Temp. (T2)	Time (t2)		
°C	sec.	°C	sec.	°C	Time
150	60 to 120	183	30	230	1

#### ● Soldering Iron

Standard Condition			
Temperature of Soldering Iron Tip	Soldering Time	Soldering Iron Power Output	Cycle of Soldering Iron
°C	sec.	W	Time
350±10	3 max.	30 max.	1

#### ■ Notice (Handling)

Uncontrolled mechanical force except usual rotation on the hollow rotor of product, may cause big change of electrical characteristic, big increase of rotational torque or mechanical damage of product.

Therefore, please pay your attention on the following points for your design.

1. The fixing method of product must be soldering by the terminals of product. And please don't fix by screw cramping of supporting board which might cause mechanical deformation of product.
2. Your connecting shaft must be sustained by your bearing and any uncontrolled force should not apply on the hollow rotor of product.

#### ■ Notice (Other)

1. Please make sure the connecting impedance is not to be less than 10M ohm. The rotary position sensor is designed to connect the output terminal and A/D port of the microprocessor directly. Therefore, connecting impedance presupposes certain M ohm and the contact resistance is set high.
2. To minimize the processing error and noise influence which occur in rare cases, when data is installed through the product, please note the following items and program your software.

- (1) Data install should be done plural times and applied the mean value.
- (2) Data considered as error should be invalid.
- (3) If suspicious data is found, the data should be re-installed.
3. Before using rotary position sensor, please test after assembly in your particular mass production system.
4. MURATA cannot guarantee rotary position sensor integrity when used under conditions other than those specified in this document.

# Rotary Position Sensors



## Connector Dust-proof Type SV21 Series

### ■ Features

1. Available for 200 degrees max. of effective rotational angle.
2. A programmable hole IC can be available for optional output voltage curve.
3. Temperature compensate range -20 to +85 degree C
4. 10M cycles rotational life
5. Optimal connector: Connector socket and Bushing mount

### ■ Applications

1. Valve actuator
2. Measuring Equipment
3. Farm Equipment
4. Construction Equipment
5. Mechatronics



SV21

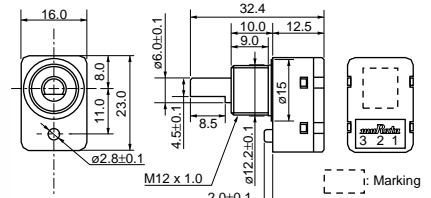

1	Gnd
2	Output
3	+5V DC

(Tolerance : ±0.3 in mm)

The shaft position in this drawing shows 0 deg. angle.  
Connector: J.S.T.Mfg Co., Ltd. Model No.: S3B-ZR-SM2

Part Number	Action Voltage	Linearity	Effective Rotational Angle	Rotational Torque	Rotational Life
SV21C201BJA01	5±0.5VDC	±2%FS/±100°	200° max.	5mN·m (Ref.; 50gf·cm) max.	10M cycles

### ■ Construction

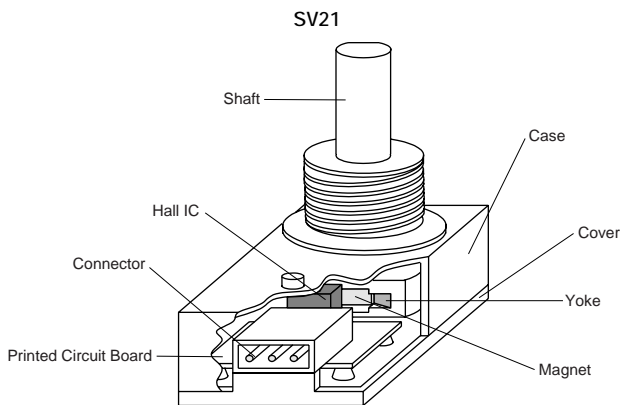

### ■ Standard Mounting Holes

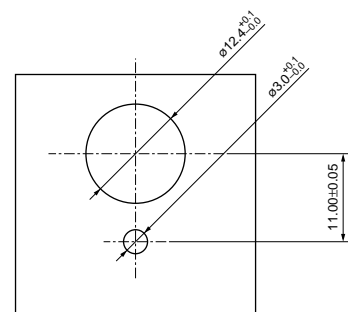

(in mm)

### ■ Characteristics

Operating Temperature Range	-25 to +85°C
Temperature Characteristics	±4% / 25°C / Full Scale
Input Current	10mA max.
Output Voltage Range	Available to set In range : 10±4% (0.5±0.2V) to 90±4% (4.5±0.2V) of input voltage range
Rotational Life	Linearity: ±3% Full Scale
Vibration	Linearity: ±3% Full Scale
Shock	Linearity: ±3% Full Scale

### Optional Output Voltage Curve

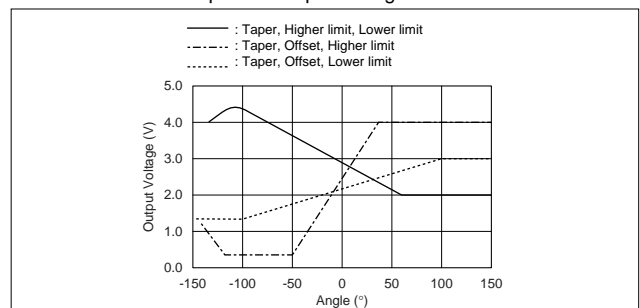

## SV21 Series Notice

### ■ Notice (Operating and Storage Conditions)

1. Store in temperatures of -10 to +40 deg. C and relative humidity of 30-85%RH.
2. Do not store in or near corrosive gases.
3. Use within six months after delivery.
4. Open the package just before using.
5. Do not store under direct sunlight.
6. Do not use the rotary position sensor under the following environmental conditions. If you use the rotary position sensor in an environment other than these listed below, please consult with Murata factory representative prior to using.
  - (1) Corrosive gasses atmosphere  
(Ex. Chlorine gas, Hydrogen sulfide gas, Ammonia gas, Sulfuric acid gas, Nitric oxide gas, etc.)
  - (2) In liquid  
(Ex. Water, Oil, Medical liquid, Organic solvent, etc.)
  - (3) Dusty / dirty atmosphere
  - (4) Direct sunlight
  - (5) Static voltage nor electric/magnetic fields
  - (6) Direct sea breeze
  - (7) Other variations of the above

### ■ Notice (Soldering and Mounting)

1. When installing sensor, tighten the nut at the torque levels less than 1.0N.m (10kgf.cm as reference).  
The exceeded force might damage the screw thread of sensor.
2. When coupling to the shaft of sensor, handle within max. value of shaft force.
3. Don't wire the sensor while the power supply is ON. Be careful during wiring.
4. Please design the cable wire to avoid the influence of the power line or high voltage line.
5. Please use the recommended connector which is "ZHR-3 series / J.S.T. made".  
When using other connector, the contact problem might happen or the connector might be damaged.
6. Can not be cleaned by any solvents due to the open construction.

### ■ Notice (Handling)

1. Uncontrolled mechanical force except usual rotation on the shaft of product, may cause big change of electrical characteristic, big increase of rotational torque or mechanical damage of product. Therefore, please pay your attention on the following points for your design.  
Please design your coupler by holding shaft bush to avoid exceeded radial or thrust shaft force of sensor.
2. The magnetic is installed inside of sensor. Please pay your attention as below.
  - (1) If sensor closes magnetic storage (magnetic tape, floppy disc drive etc.), the magnetic memory might be damaged.
  - (2) Don't close sensor to patient who is wearing electrical medical equipments. The equipment might malfunction due to magnetic influence of sensor.

### ■ Notice (Other)

1. Input voltage  
Please design the input voltage value of less deteriorated with age and smaller ripple because of direct influence for output voltage.  
Though the protection circuit of 8.5V is installed, the exceeded input voltage might damage inner circuit of sensor.
2. Influence of magnetic field  
Don't place another magnetic materials or magnetic generator. These might happen malfunction of your set due to changing the output voltage of sensor.

## Rortary Position Sensors SMD/Lead Dust-proof Type (SV01) Specifications and Test Methods

The tests and measurements should be conducted under the condition of 15 to 35°C of temperature 25 to 75% of relative humidity and 86 to 106 k Pa of atmospheric pressure unless otherwise specified. In case when entertained a doubt in judgment obtained from results measured in accordance with the above mentioned conditions, the tests and measurements should be conducted under the condition of 25±2°C of temperature and, 50±2% of relative humidity and 86 to 106 k Pa of atmospheric pressure. When the potentiometer is tested after soldering on PCB., it should be tested after being kept in a room (15 to 35°C, 25 to 75%RH) over 24 hours except "Resistance to soldering heat".

No.	Item	Test Methods															
1	Linearity	<p>Independent linearity should vary no more than ±2% within ±160° to 50% voltage ratio.                      Taper : linear, 100%/333.3° Measured with the circuit as below (Figure 1).</p> <p>Output voltage ratio (%)</p> $\left( \frac{V(1-2)}{V(1-3)} \times 100 \right)$ <p>Rotational angle (°)</p> <p>Figure-1</p>															
2	Temperature Coefficient of Resistance	<p>The rotary position sensor should be subjected to each of the following temperatures (see Table 1) for 30-45 minutes. Temperature coefficient of resistance should be applied to the following formula.</p> $TCR = \frac{R_2 - R_1}{R_1 (t_2 - t_1)} \times 10^6 \text{ (ppm/°C)}$ <p>t<sub>1</sub> : Reference temperature in degrees celsius                      t<sub>2</sub> : Test temperature in degrees celsius                      R<sub>1</sub> : Resistance at reference temperature in ohm                      R<sub>2</sub> : Resistance at test temperature in ohm</p> <table border="1"> <thead> <tr> <th>Sequence</th> <th>*1</th> <th>2</th> <th>*3</th> <th>4</th> </tr> </thead> <tbody> <tr> <td>Temperature (°C)</td> <td>+25</td> <td>-40</td> <td>+25</td> <td>+85</td> </tr> </tbody> </table> <p>Note * : Reference temperature</p> <p>Table-1 Test temperatures</p>	Sequence	*1	2	*3	4	Temperature (°C)	+25	-40	+25	+85					
Sequence	*1	2	*3	4													
Temperature (°C)	+25	-40	+25	+85													
3	Temperature Cycle (Thermal Shock)	<p>The rotary position sensor should be subjected to Table 2 temperature for 5 cycles. Then, the rotary position sensor should be kept in the dry box for 24 +8/-0 hrs.</p> <table border="1"> <thead> <tr> <th>Sequence</th> <th>1</th> <th>2</th> <th>3</th> <th>4</th> </tr> </thead> <tbody> <tr> <td>Temperature (°C)</td> <td>-40±3</td> <td>+25±2</td> <td>+85±3</td> <td>+25±2</td> </tr> <tr> <td>Time (min.)</td> <td>30</td> <td>5 max.</td> <td>30</td> <td>5 max.</td> </tr> </tbody> </table> <p>Table 2: One cycle of temperature cycle</p>	Sequence	1	2	3	4	Temperature (°C)	-40±3	+25±2	+85±3	+25±2	Time (min.)	30	5 max.	30	5 max.
Sequence	1	2	3	4													
Temperature (°C)	-40±3	+25±2	+85±3	+25±2													
Time (min.)	30	5 max.	30	5 max.													
4	Humidity	<p>The rotary position sensor should be stored in a chamber at temperature of +60±2°C and relative Humidity of 90-95% for 250±8 hrs. After removing from the chamber, the rotary position sensor should be kept in the dry box for 24 +8/-0 hours.</p>															
5	Vibration	<p>The rotary position sensor should be tested under the condition of the amplitude of 1.5mm, the frequency range from 10 to 55Hz (should be traversed in approximately one minute) and 2 hours in each of 3 mutually perpendicular directions (total 6 hours). Then, the rotary position sensor should be kept in the dry box for 1-2 hrs.</p>															
6	Shock	<p>The rotary position sensor should be tested under the condition of the peak acceleration 20G max. in half-sine wave and 5 shocks in each of 3 mutually perpendicular directions (total 15 shocks). Then, the rotary position sensor should be kept in the dry box for 1-2 hrs.</p>															
7	Humidity Load Life	<p>Full rated continuous working voltage not exceeding 5Vdc should be applied intermittently between terminal #1 and terminal #3 of the rotary position sensor, 1.5 hours on and 0.5 hours off, for 96±4 hours in total in a chamber at a temperature of +40±2°C and relative humidity of 90-95%. After removing from the chamber, the rotary position sensor should be kept in the dry box for 24 +8/-0 hours.</p>															
8	High Temp. Exposure	<p>The rotary position sensor should be stored in a chamber at the temperature of +85±3°C without loading for 250±8 hours. After removing from the chamber, the rotary position sensor should be kept in the dry box for 24 +8/-0 hours.</p>															
9	Low Temp. Exposure	<p>The rotary position sensor should be stored in a chamber at the temperature of -40±3°C without loading for 168±4 hours. After removing from the chamber, the rotary position sensor should be kept in the dry box for 24 +8/-0 hours.</p>															
10	Rotational Life	<p>The adjustment rotor should be continuously rotated within ±160° of effective electrical rotational angle, at the rate of one cycle for 6 seconds for 1 Million cycles under the condition of +25±2°C of temperature without loading.</p>															

## Rotary Position Sensors Connector Dust-proof Type (SV21) Specifications and Test Methods

No.	Item	Test Methods
1	Linearity	<p>Linearity is specified the following maximum deviation (C) as percentage of the output voltage (E) from the output voltage approximate straight-line (Y) in FS (full scale) within the electrical effective rotational angle.                      (Linearity = <math>C/FS \times 100\%</math>)                      Approximate straight-line (<math>Y=m\theta+b</math>) is calculated by least square from measured output voltage curve.                      FS is specified the range from min. output voltage (Y min.) to max. output voltage (Y max.) of approximate straight-line within the electrical effective rotational angle.</p> <div style="text-align: center;"> <p>The graph plots Output Voltage E on the vertical axis against Rotational Angle <math>\theta</math> on the horizontal axis. A solid curve represents the measured output voltage <math>E_1(V)</math>. A dashed straight line represents the approximate straight-line <math>Y_1(V)</math> with the equation <math>Y=mX+b</math>. The vertical distance between the curve and the line at a specific angle is labeled as C. The full scale (FS) is the vertical range from <math>Y_{min.}</math> to <math>Y_{max.}</math>. The horizontal range is labeled as Electrical Effective Rotational Angle. A 0° mark is shown on the horizontal axis.</p> </div> <p>Y= Approximate straight-line of output voltage (V)  <math>\theta</math>= Rotational angle (°)                      C= Maximum deviation of output voltage (E1) from output voltage approximate straight-line (Y1)</p>
2	Temperature characteristics	Temperature characteristics is specified as percentage the maximum deviation of output voltage from that at $25\pm 2^\circ\text{C}$ in FS (full scale).
3	Rotational life	The adjustment rotor should be continuously rotated within $\pm 100^\circ$ of effective electrical rotational angle, at the rate of one cycle for 1 seconds for 10 Million cycles under the condition of $25\pm 2^\circ\text{C}$ of temperature without loading.
4	Vibration	The rotary position sensor should be tested under the condition of the amplitude of 1.5mm, the frequency range from 10 to 55Hz (should be traversed in approximately one minute) and 2 hours in each of 3 mutually perpendicular directions (total 6 hours).
5	Shock	The rotary position sensor should be tested under the condition of the peak acceleration 100G max. in half-sine wave and 4 shocks in each of 3 mutually perpendicular directions (total 12 shocks).



## Packaging

### ■ Minimum Quantity

Part Number	Minimum Quantity (pcs.)					
	ø180mm reel	ø330mm reel	Ammo Pack	Magazine	Bulk	Tray
PVZ2A	3000	12000	—	—	1000	—
PVZ2K/R	3000	—	—	—	1000	—
PVA2	3000	—	—	—	1000	—
PVZ3A	2000	8000	—	—	1000	—
PVZ3K/R	1500	—	—	—	1000	—
PVS3	2500	8000	—	—	1000	—
PVA3	2000	8000	—	—	1000	—
PVG3A/G	1000	—	—	—	500	—
PVG3K	500	—	—	—	—	—
PVM4	500	3000	—	—	500	—
PVF2A	500	—	—	—	100	—
PVG5A	250	—	—	—	50	—
PVG5H	500	—	—	—	50	—
PV01W/P/X	—	—	—	50	—	—
PVC6A/D/G/H/E	—	—	—	50	50	—
PVC6M/Q	—	—	1000	50	50	—
PV34	—	—	—	—	100	—
PV32	—	—	—	—	100	—
PV23/12	—	—	—	—	50	—
PV22	—	—	—	—	30	—
PV36W	—	—	1000	50	50	—
PV36Y	—	—	—	50	50	—
PV36X	—	—	1000	40	50	—
PV36Z/P	—	—	—	40	50	—
PV37Y/Z	—	—	1000	—	50	—
PV37W/X/P	—	—	—	—	50	—
SV01A	—	1000	—	—	50	—
SV01L	—	—	—	—	—	1000
SV21	—	—	—	—	10	—

### ■ Dimensions of Reel

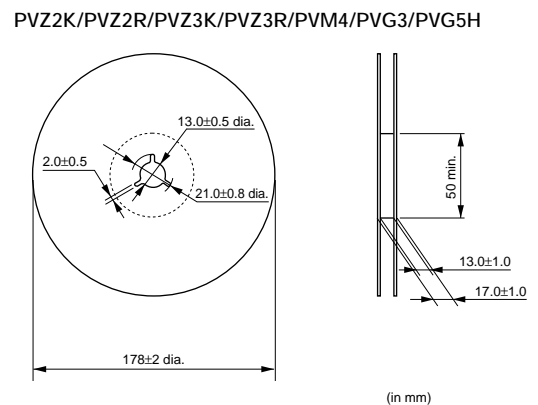
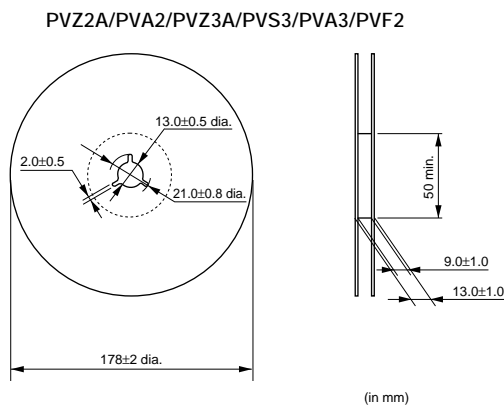

Continued on the following page.

## Packaging

Continued from the preceding page.

### ■ Dimensions of Reel

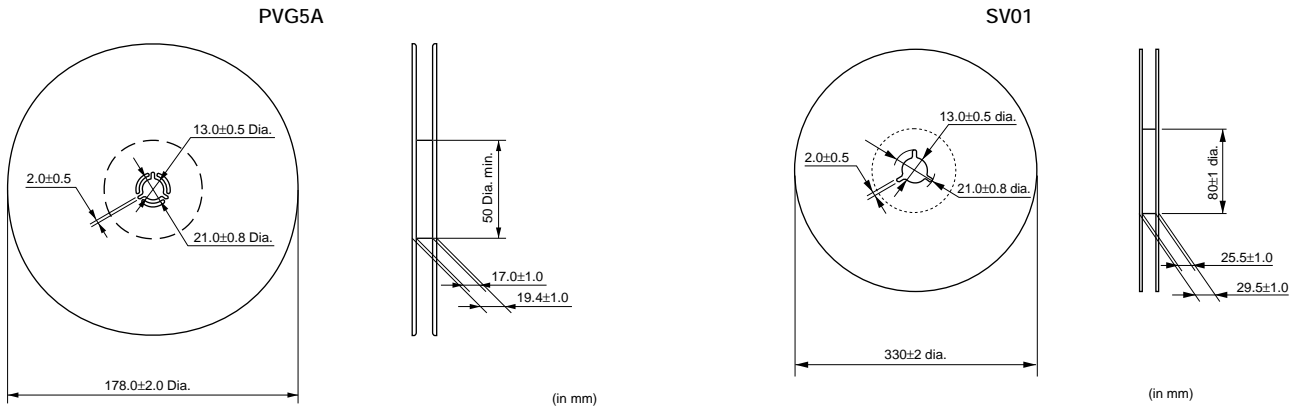

### ■ Dimensions of Plastic Tape

#### PVZ2 / PVA2 / PVZ3 / PVA3 / PVS3 / PVF2

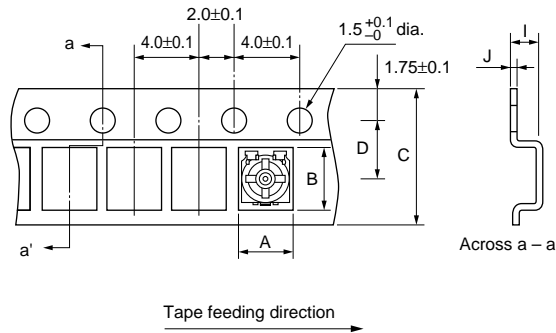

Part Number	A	B	C	D	I	J
PVZ2A	2.4±0.2	3.1±0.1	8.0±0.2	3.5±0.1	1.1±0.1	0.2±0.1
PVZ2K		5.7±0.2	12.0±0.2	5.5±0.1		0.3±0.1
PVZ2R		5.1±0.2			1.0±0.1	
PVA2	3.3±0.2	3.1±0.1	8.0±0.2	3.5±0.1	1.1±0.1	0.2±0.1
PVZ3A/PVA3		3.8±0.2	12.0±0.2	5.5±0.1	1.95±0.1	
PVZ3K		5.8±0.2			2.3±0.1	0.3±0.1
PVZ3R	6.5±0.2	12.0±0.2	5.5±0.1	2.1±0.1		
PVS3	2.3±0.2	4.1±0.2	8.0±0.2	3.5±0.1	1.6±0.1	0.2±0.1
PVF2		2.3±0.2			2.3±0.2	2.3±0.1

• The side containing terminals #1 and #3 faces the plastic tape pilot holes.

(in mm)

Continued on the following page. ↗

# Packaging

Continued from the preceding page.

## ■ Dimensions of Plastic Tape

PVG3K

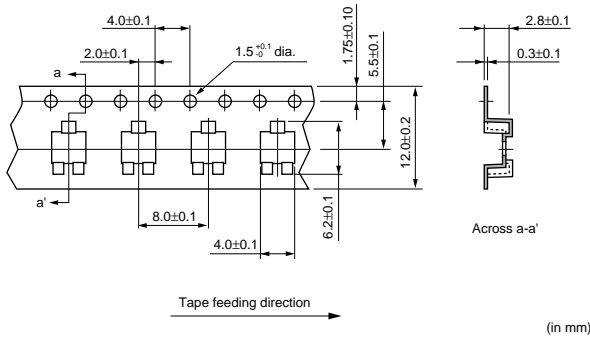

SV01

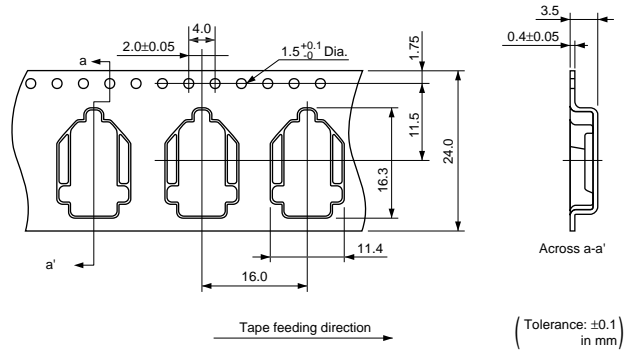

## ■ Dimensions of Radial Taping

PVC6M

0.55W×3.2L×1.3D

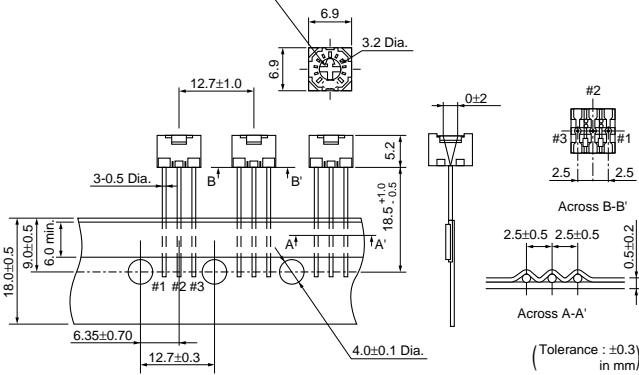

PVC6Q

0.55W×3.2L×1.3D

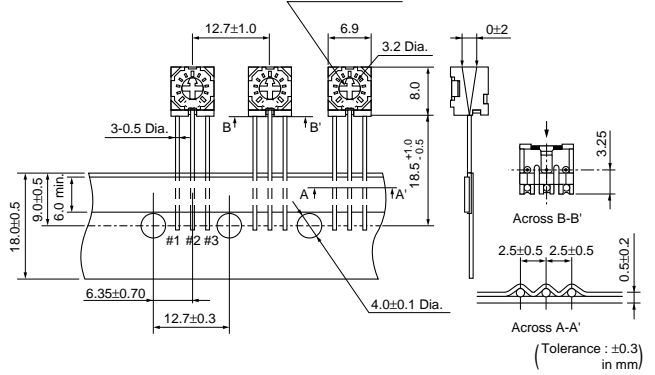

PV37Y

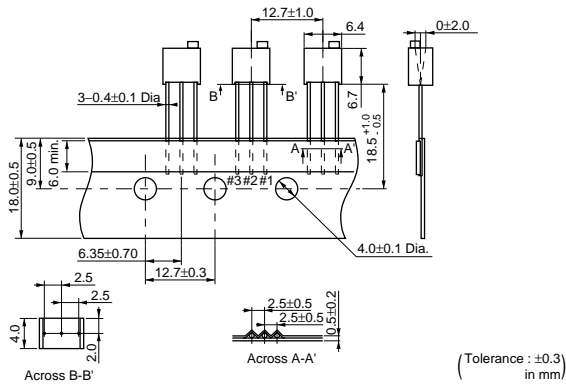

PV37Z

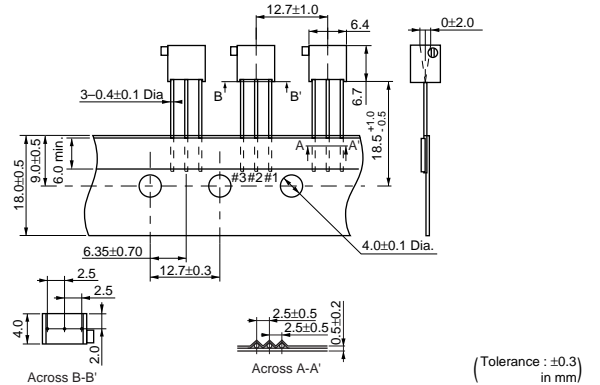

Continued on the following page.